



22 JAN 2016

Photocell, Fault Monitoring, GSM, Switch-Over and Flash Controller Unit

CEL-CSW-DCW-8+2-GSM - Four Output Channels

Key features

- 4 independent outputs with current monitoring at each output
- Integrated photocell, external photocell option (CEL-PCE-DCW-F)
- Several flashing modes
- Global flash sequence synchronisation with GPS
- Main/spare switch-over
- Alarm output (dry contact)
- GSM fault monitoring system available (SMS alarms)

Characteristics

- User-selectable operating parameters
- Fault monitoring based on current flow through LED lamp
- Potential-free relay alarm (dry contact)
- Shock-resistant polycarbonate enclosure (IP65)
- Enclosure dimensions (WxHxD): 300mm x 200mm x 132mm
- Printed circuit board dimensions (WxH) 200mm x 125mm
- Weight 1.9kg
- Cable glands: 5 x M25 (9-17 mm cable diameter) and 2 x M16 (4.5-10mm cable diameter)

Electrical characteristics

- Wide operating voltage range 10VDC to 60V_{DC}
- (must be equal to lamp voltage)
- Power consumption <1W
- Operating temperature range -40°C ...+55°C

Photocell sensitivities

- OFF / 400 lx / 800 lx / 1600 lx / external photocell
- Optionally, OFF/ 200 lx / 400 lx / 800 lx / external photocell (values used with previous CSW model)

Flash frequencies

Steady burning / 20fpm / 40fpm / 60fpm

Flash durations

- 100ms / 250ms / 500ms
- CASA compliant flash durations (2/3 ON, 1/3 OFF)

Flash modes

- All outputs simultaneously
- ICAO sequential flash for 3 light units
- FAA sequential flash for 3 light units
- German BMVB flash sequence
- Polish sequential flash for 3 light units

Made in EU

Page 1 of 4

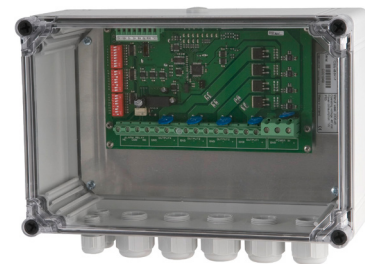

Options

- GPS receiver (with on-board internal antenna)
- GSM modem (for SMS messaging)
- External GPS Antenna (see order codes on last page)

Order code	Current	GPS	GSM
CEL CSW-DCW-2-F	4 * 0.5A		
CEL CSW-DCW-2-GPS	4 * 0.5A	X	
CEL CSW-DCW-2-GSM	4 * 0.5A		X
CEL CSW-DCW-2-GPS-GSM	4 * 0.5A	X	X

Order code	Current	GPS	GSM
CEL CSW-DCW-8+1-F	2 * 4A + 2 * 0.5A		
CEL CSW-DCW-8+1-GPS	2 * 4A + 2 * 0.5A	X	
CEL CSW-DCW-8+1-GSM	2 * 4A + 2 * 0.5A		X
CEL CSW-DCW-8+1-GPS-GSM	2 * 4A + 2 * 0.5A	X	X

Order code	Current	GPS	GSM
CEL CSW-DCW-8+2-F	2 * 4A + 2 * 1A		
CEL CSW-DCW-8+2-GPS	2 * 4A + 2 * 1A	X	
CEL CSW-DCW-8+2-GSM	2 * 4A + 2 * 1A		X
CEL CSW-DCW-8+2-GPS-GSM	2 * 4A + 2 * 1A	X	X

Order code	Current	GPS	GSM
CEL CSW-DCW-16-F	4 * 4A		
CEL CSW-DCW-16-GPS	4 * 4A	X	
CEL CSW-DCW-16-GSM	4 * 4A		X
CEL CSW-DCW-16-GPS-GSM	4 * 4A	X	X

T: +44 (0)20 8540 1034
F: +44 (0)20 8543 3058
E: info@contarnex.com

Contarnex Europe Limited
252 Martin Way,
Morden, Surrey SM4 4AW
United Kingdom



www.contarnex.com

Photocell, Fault Monitoring, GSM, Switch-Over and Flash Controller Unit

CEL-CSW-DCW-8+2-GSM - Four Output Channels

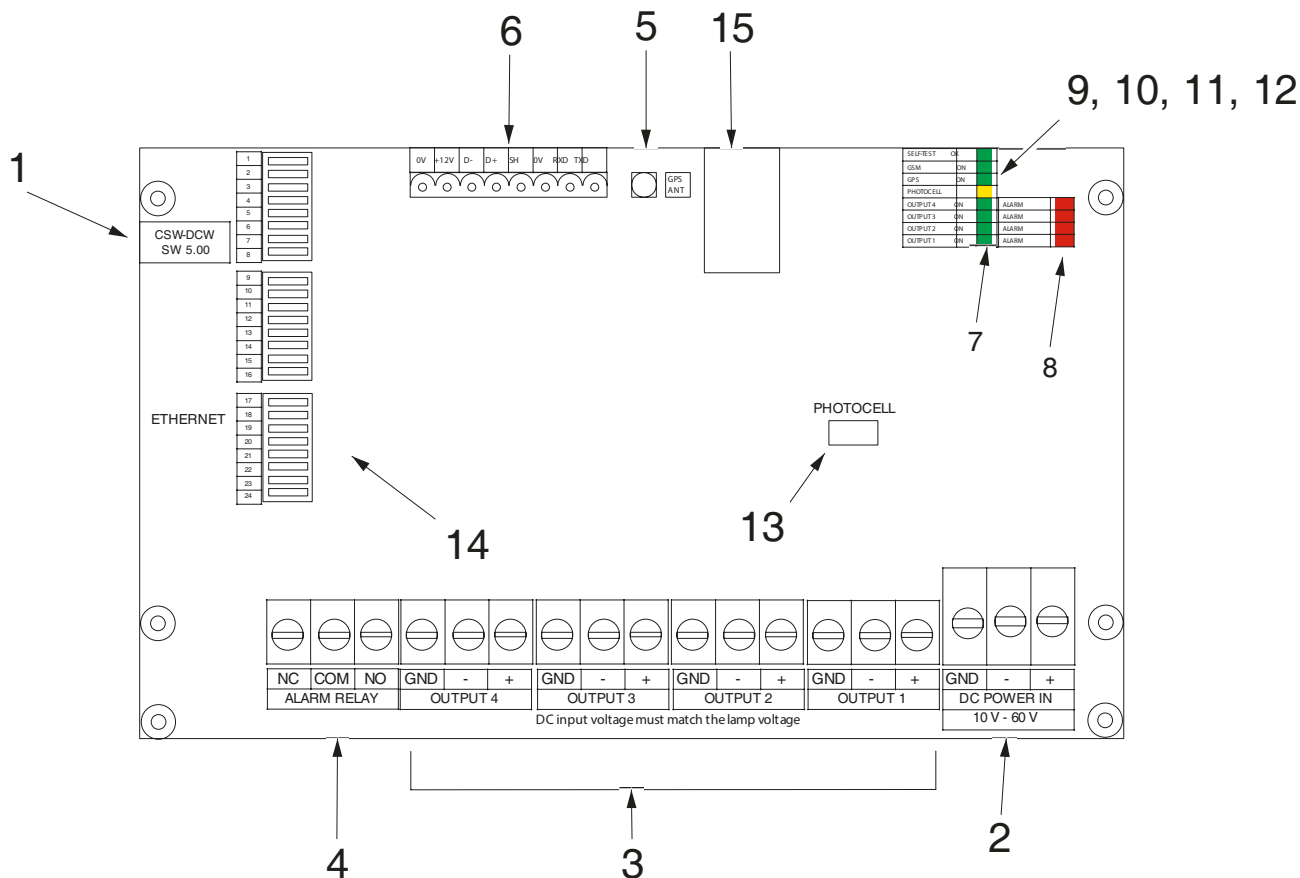

Item	Description
1	CSW Application software version label
2	Supply power (DC input to CSW)
3	Output connectors (four channels)
4	Alarm relay output connector
5	GPS External Antenna connector (Radiall RP-MCX)
6	External photocell I/O and power supply to photocell GSM modem I/O and power supply to GSM modem
7	Output status indicator LEDs [Green]
8	Output alarm indicator LEDs [Red]
9	Photocell status indicator LED [Yellow]
10	GPS synchronisation status indicator LED [Green]
11	GSM status indicator LED [Green]
12	Self-test ok status indicator LED [Green]
13	Internal photocell
14	Configuration DIP switches (three switch blocks with eight switches in each)
15	GPS receiver module

Indicator LEDs

- Operation LEDs for all outputs
- Undercurrent and overcurrent alarms for all outputs
- Photocell ON
- GPS operation
- GSM operation
- Self test OK

Alarm relay characteristics

- Two pole contacts:
Normally Open (NO) and Normally Closed (NC)
- Active when CSW is powered
- Switch voltage (max): 200VDC
- Switch current (max): 0.25A
- Switch power (max): 3W
- Contact resistance (max) 0.15ohm

Output current alarm level settings

- User can select from pre-set upper and lower alarm levels

Photocell, Fault Monitoring, GSM, Switch-Over and Flash Controller Unit

CEL-CSW-DCW-8+2-GSM - Four Output Channels

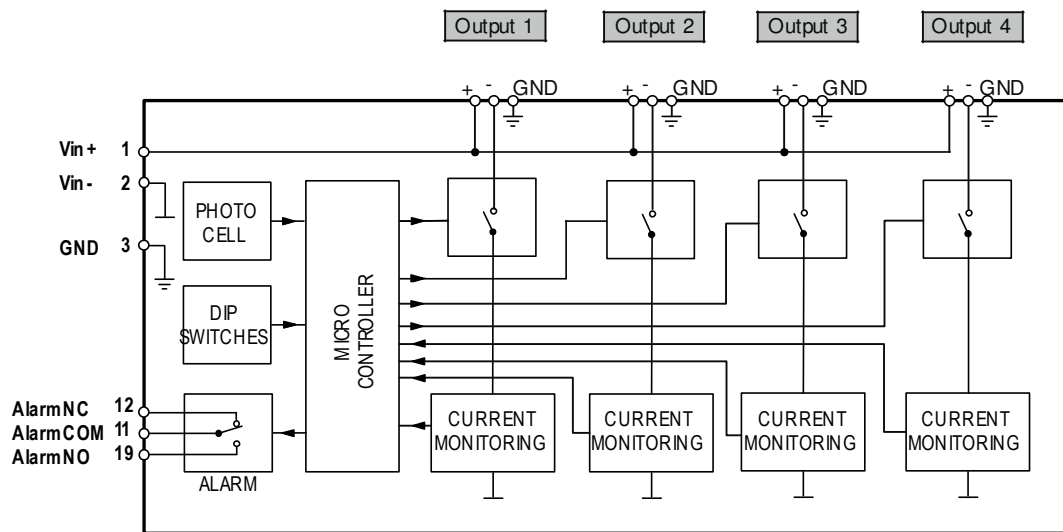

CSW Four-Output Series Block diagram

Description of operation

The CSW controller measures the current consumption of the operational output every 0,5 seconds. If five consecutive inaccurate measurements are recorded, the output is switched off, an alarm is generated and the second output (if selected) is taken into use. After 30 minutes the CSW controller will attempt to switch the first (faulty) output back on, makes five measurements, and if the fault is cleared, the alarm is turned off. If it is still faulty the alarm stays on and the second output (if selected) is kept on. An alarm is also generated in case of power loss.

Remember always to check the DIP switch settings that output selections are correctly selected.

You may connect several light units to one single output, noting that the combined currents form the new current limits for correct controller operation.

If in built internal photocell is used, the unit must be installed outdoors according to requirements (e.g. facing north on Northern hemisphere).

ICAO/FAA Sequential flash mode for 3-light unit

According to ICAO Aerodrome Design Manual, Part 4, Visual Aids, fourth edition - 2004 and FAA AC 150/5345-43F, 09/12/06:

Some cases, lighting systems requires both a unique, easily recognised, vertically coded flashing sequence, and the marking of two or more structures on either side of the flyway, e.g. river valley, major road, etc. While not absolutely necessary, synchronised flashing of all lighted structures is desirable.

The middle level (output 2) flash first, the top level (output 1) flash second, and the bottom level (output 3) flash last. The interval between the flashing of the top level and bottom level is twice the interval between the middle level and the top level. The interval between the end of one sequence and the beginning of the next is ten times the interval between the middle level and the top level. The time for the completion of one cycle is 1 second.

German BMVB Flash Sequence

According to BMVB LS 11/60.01.87-01/5 Va 02, 24. September 2002, Page 15: 1s on, 0,5s off, 1s on, 1,5 s off

Polish Flash Sequence

Sequential flash mode for 3-light unit: Starting from bottom - middle - top, 20 fpm/light unit, total amount of flashes being 60 fpm.

Multiple CSW's flash synchronisation

UTC (Coordinated Universal Time) from GPS receiver maintains CSW real time clock correct time within 20 ms accuracy. When real time clock is locked to UTC, all CSW units start flash sequence exactly at the same time without any intervention.

For example flash sequence according BMVB LS 11/60.01.87-01/5 Va 02, 24. September 2002: Flash sequence starts 15 times/minute (on every fourth second), at full seconds below: 0, 4, 8, 12,16 ,20, 24, 28, 32, 36, 40, 44, 48, 52 and 56.

Photocell, Fault Monitoring, GSM, Switch-Over and Flash Controller Unit

CEL-CSW-DCW-8+2-GSM - Four Output Channels

Mounting with vertical fastening lugs

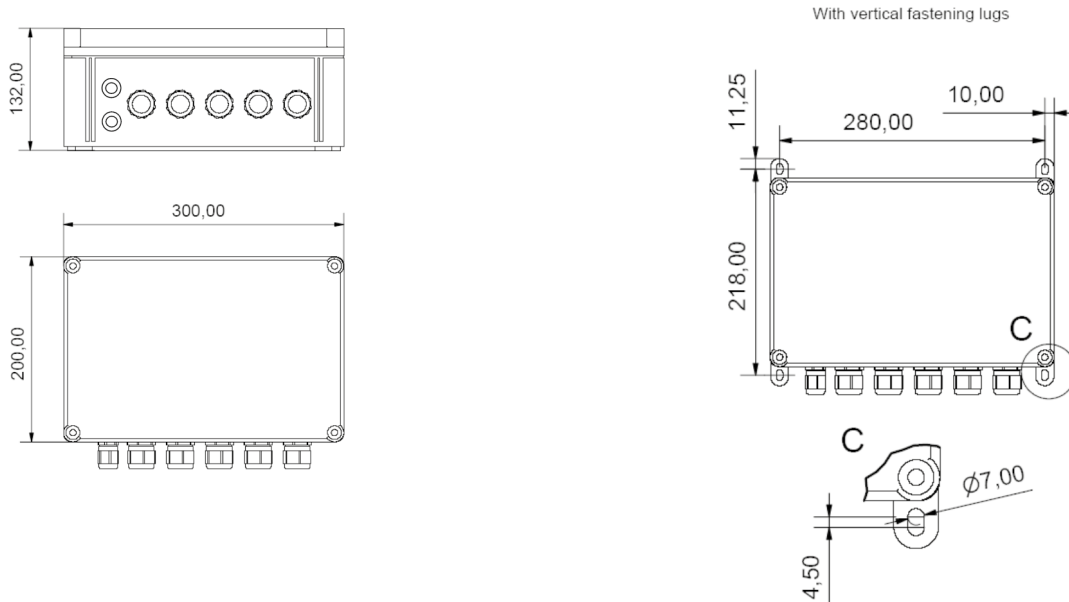

Mounting with horizontal fastening lugs

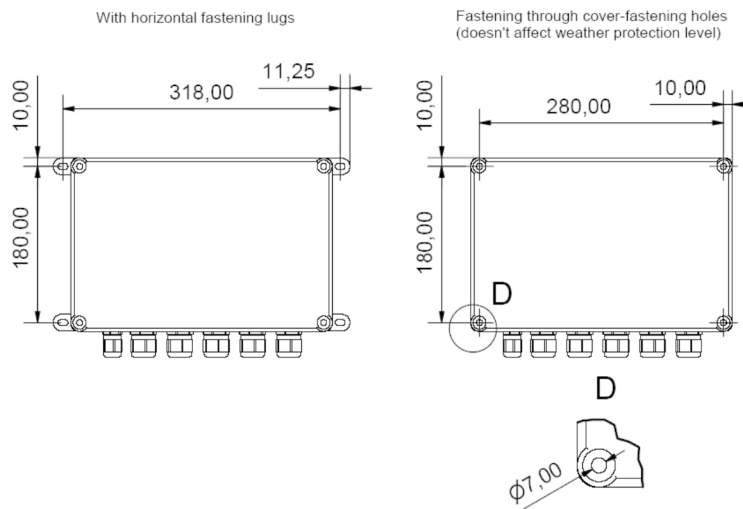

External antennas for GPS:

Order code	Cable length
CEL-OPT-GPS-3m	3m
CEL-OPT-GPS-5m	5m
CEL-OPT-GPS-10m	10m