



230V_{AC} ICAO Low-intensity, Type A Obstruction Light

CEL-10-230-F LED Aircraft Warning Light (1st Generation)

Key features

- Based on LED-technology
- Extremely reliable - long lifetime
- Very low power consumption
- 230 V_{AC} nominal supply voltage
- Stabilised light output
- Lightweight and small - low wind load factor
- Easy to install
- Absolutely no RF-radiations

Benefits

- Long maintenance intervals
- Low energy cost
- Supply power voltage variations do not affect light output
- Very low total lifetime costs
- Low wind load
- Two-stage over-voltage protection
- Easy to chain
- Comes with five (5) year warranty

Specifications met

- ICAO International Standards and Recommended Practices: Aerodromes - Annex 14 Volume 1, 5th Edition, July 2009, Chapter 6: Low-intensity, Type A Fixed Obstacle Light

Optical characteristics

- Intensity better than 10cd
- Colour aviation red
- Horizontal radiation pattern 360°
- Vertical radiation pattern 50°
- LED supply current stabilised by constant current generator
- Light output degradation less than 30% after 100.000hrs of operation

Electrical characteristics

- LEDs in separate groups
- Nominal operating voltage 230 V_{AC}
- Power consumption 7VA
- Operating voltage range 210...250 V_{AC}

Mechanical characteristics

- Yellow painted aluminium body
- Colourless (clear) glass cover
- Terminal box for 1,5 - 6mm² wires
- Weather protection to IP65
- Operating temperature range -55°C ... +55°C
- Height 235mm, diameter 120mm, weight 1,1kg
- Wind load with CEL-MS-60 mounting kit @ 200km/h less than 40N

Order Code: **CEL-10-230-F**

Made in EU

Page 1 of 3



CEL-10-230-F



T: +44 (0)20 8540 1034
F: +44 (0)20 8543 3058
E: info@contarnex.com

Contarnex Europe Limited
252 Martin Way,
Morden, Surrey SM4 4AW
United Kingdom



230V_{AC} ICAO Low-intensity, Type A Obstruction Light

CEL-10-230-F LED Aircraft Warning Light (1st Generation)

CEL-10-230-F is an obstacle light utilising LED technology. The cabling and installation principles are similar to those of conventional obstacle lights, the only exception being the correct polarity required by DC feed.

The recommended polarity is:

Blue -
Black +

All connection alternatives can be protected with a 6A or 10A fuse or with a circuit breaker (C curve).

Technical specifications

- Operating voltage: 230V_{AC}
- Power consumption: <9VA, <6W
- Current consumption: <100mA
- Two-stage overvoltage protection
- Weather protection: IP65
- Operating temperature range: -55 ... +55°C
- Height: 235mm
- Diameter: 120mm
- Glass cover thickness: 5mm
- Terminal box: yellow powder painted die cast Aluminium
- Weight: 1.1kg

Installation specifications

- Cable gland: PG 16
- Cable diameter: 8 ... 14mm
- Wire diameter: max. 6mm²
- Recommended cable: 4x1.5+1.5 or 2x1.5+1.5mm²
- Fixing hole distance: 100mm
- Fixing screw diameter: max. 5mm
- Fixing base thickness: 5mm

Mounting sets

- CEL-MS-60: Mounting onto Ø 30 ... 60mm pipes
- CEL-MS-100: Mounting onto Ø 60 ... 100mm pipes
- U-bolts and hex nuts M8: acid-proof steel
- Mounting plate: black anodised aluminium

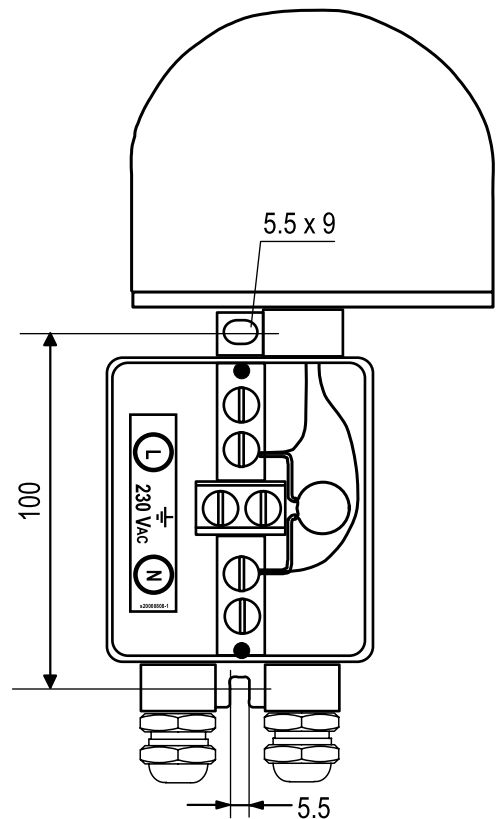

CEL-10-230-F terminal box

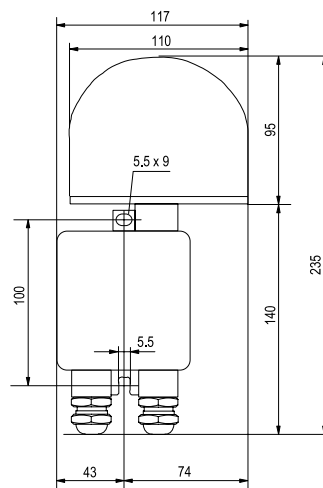

CEL-10-230-F dimensions

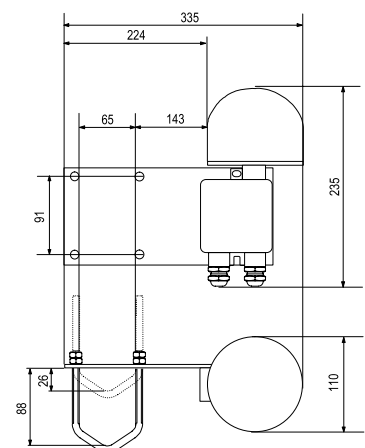

CEL-MS-60 Mounting Set dimensions



CEL-10-230-F LED Aircraft Warning Light (1st Generation)

There are several types of mounting sets available as option. For example:

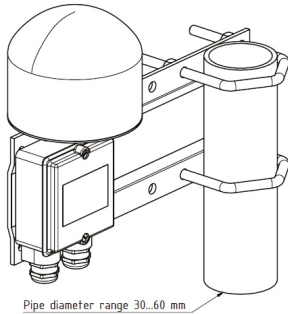

CEL-MS-60

Mounting set with extension plate for 30-60 mm vertical pipe installation

Mounting set include:

- 2 pcs 65mm, M8 U-bolt, 8 pcs M8 hex nut
- 2 pcs M5x30 bolt, 2 pcs M5 nyloc hex nut, 2 pcs washer
- 1 pcs extension plate

Extension plate marine grade anodised aluminium, other parts AISI 316 acid proof steel

More detailed mechanical data: CEL-MS-60 datasheet

Order Code: **CEL-MS-60**

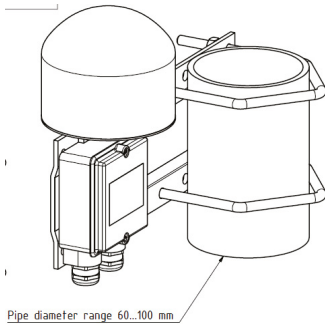

CEL-MS-100

Mounting set with extension plate for 60-100mm vertical pipe installation

Mounting set include:

- 2 pcs 105mm, M8 U-bolt, 8 pcs M8 hex nut
- 2 pcs M5x30 bolt, 2 pcs M5 nyloc hex nut, 2 pcs washer
- 1 pcs extension plate

Extension plate marine grade anodised aluminium, other parts AISI 316 acid proof steel

More detailed mechanical data: CEL-MS-100 datasheet

Order Code: **CEL-MS-100**

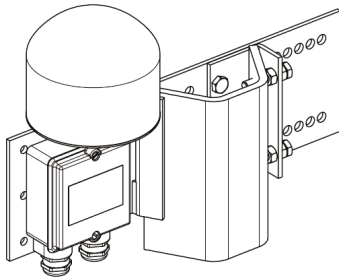

CEL-MS-TRA-LVU

Mounting set for Land V -shape profiles

Mounting set include:

- 1 set accessories for light unit fitting to plate
- 1 pcs extension plate with adjusting plate and accessories

Extension plate hot dip galvanized steel, other parts AISI 316 acid proof steel

More detailed mechanical data: CEL-MS-TRA-L VU datasheet

Order Code: **CEL-MS-TRA-LVU** (with galvanized extension plate)