

1 FOUNDATION

1.1 Foundation design

The factors affecting the foundation design are:

- Height of the mast
- Quantity of lights / mast (in tubular masts always 1 light/mast)
- Wind load (including jet blast loads cause by the aircraft engines in the proximity of the threshold)
- Soil quality

The following tables describe some typical examples of mast foundations. The calculations have been made for tubular masts carrying single luminaires. The maximum wind speed used in the calculations is 40 m/s. Dimensioning of the foundations has been done according to DIN V 4017-100.

Two types of foundations have been calculated, slab foundation and drum foundation.

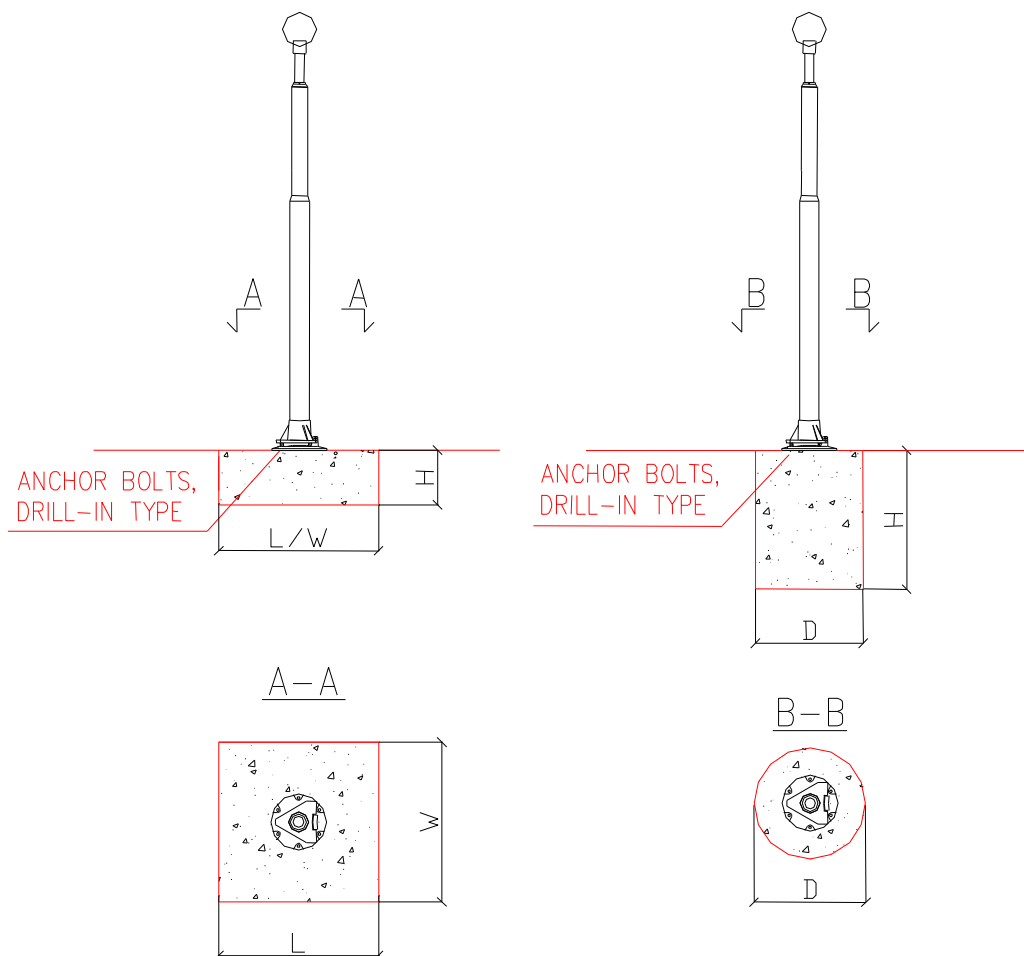

Illustration 1: Slab foundation and drum foundation

Slab foundation		SOIL TYPE 1			SOIL TYPE 2			SOIL TYPE 3		
Mast height	Type	L=W	H	Mass	L=W	H	Mass	L	H	Mass
Meters	-	mm	mm	kg	mm	mm	kg	mm	mm	kg
H = 2,5	Tubular	600	200	170	600	200	170	700	200	250
H = 4	Tubular	700	300	350	600	300	260	800	400	620

Drum foundation		SOIL TYPE 1			SOIL TYPE 2			SOIL TYPE 3		
Mast height	Type	D	H	Mass	D	H	Mass	D	H	Mass
Meters	-	mm	mm	kg	mm	mm	kg	mm	mm	kg
H = 2,5	Tubular	500	800	390	500	600	280			
H = 4	Tubular	500	1000	480	500	800	390			

Dimensioning of the concrete foundation for tubular masts.

- Soil type 1: Sand, sandy soil
 angle of friction $\delta = 25^\circ$
 weight by volume $\gamma = 17 \text{ kN/m}^3$
 cohesion $c = 0 \text{ kN/m}^2$
- Soil type 2: Compacted coarse sand and moraine
 angle of friction $\delta = 40^\circ$
 weight by volume $\gamma = 21 \text{ kN/m}^3$
 cohesion $c = 0 \text{ kN/m}^2$
- Soil type 3: Hard clay (drum foundation should not be used!)
 angle of friction $\delta = 0^\circ$
 weight by volume $\gamma = 19 \text{ kN/m}^3$
 cohesion $c = 20 \text{ kN/m}^2$

Concrete: > K30



- In a groundwater area the foundation shall be deeper.
- In a soil frost area, the foundation shall reach below the soil frost penetration depth.



- All design values mentioned in this instruction are purely indicative. Exel Oyj shall not take responsibility for their applicability to the area in question.
- It is highly recommended to always consult a local civil engineer about the dimensioning of the foundation.
- Exel Oyj will provide the necessary load calculations (shear force and bending moment), when requested.

-
- r**
- *Positioning of masts has been dimensioned in the layout-drawing.*
 - *The heights of the tops of foundation have been listed separately for each position in the mast list, if this information has originally been provided to Exel Oyj.*
-

1.2 Preparation of foundation

For tubular masts the foundation bolts do not need to be cast to the foundation. The cast surface is left horizontal and sufficiently flat for mounting of the mast on top of the surface.

-
- i**
- *The tubular mast base will be fixed later with wedge bolts.*
 - *Drill 50 – 60 mm deep holes for the wedge bolts in connection with the mast erection. The diameter of the holes 10 – 11 mm.*
-