

**24 V<sub>DC</sub> fault monitoring and flash controller unit**

**Key features**

- 4 independent outputs
- 0,5A current capacity at each output
- Current monitoring at each output
- Integrated photocell
- External photocell option (CEL-PCE-DCW-F)
- Several flashing modes
- Global flash sequence synchronisation by GPS UTC-time
- Master-slave switch-over
- Alarm output (relay)
- GSM alarm monitoring (SMS text message)



**Characteristics**

- User selectable operating parameters
- Microprocessor controlled
- Fault monitoring based on current flow through LED lamp
- Potential free relay alarm
- Shock resistant Polycarbonate enclosure (degree of protection IP65)
- Enclosure dimensions (WxHxD): 300 mm x 200 mm x 132 mm
- Printed circuit board dimensions (WxH): 200 mm x 125 mm
- Weight 1.9 kg
- Cable Glands: 1 x M16 (4.5 - 10 mm cable diameter) and 5 x M25 (9-17 mm cable diameter)

**Indicator LEDs**

- Under - and overcurrent alarms 1 for all outputs
- Selftest OK
- Photocell ON

**Electrical characteristics**

- Operating voltage range 40 to 59VDC
- Power consumption <1 W
- Operating temperature range -40...+55 °C

**Alarm relay characteristics**

- Two pole contacts: Normally Open (NO) and Normally Closed (NC)
- Active when CSW-F is powered
- Switch voltage (max): 200VDC
- Switch current (max): 0.25A
- Switch power (max): 3W
- Contact resistance (max) 0.15 ohm

**Photocell sensitivities**

- OFF / 100 / 200 / 400 lux / external photocell

**Output current alarm level settings**

- User can select upper and lower alarm levels.

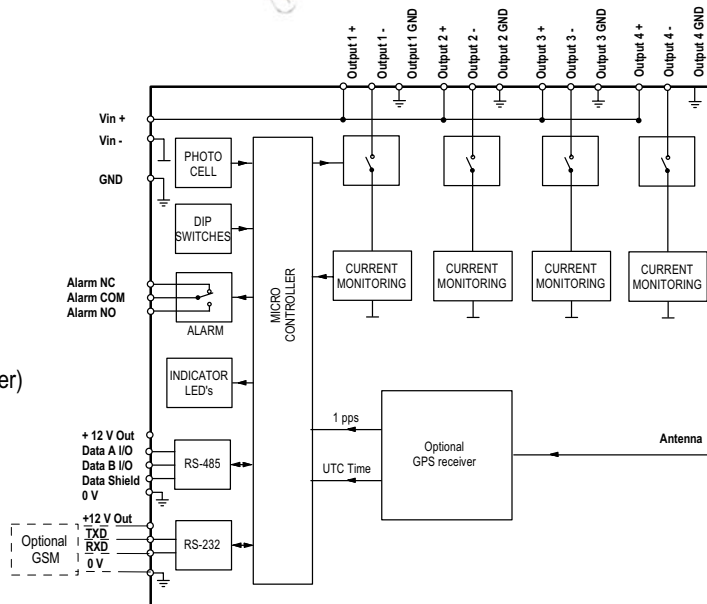

**Flash frequencies**

- Steady burning / 20 / 40 / 60 fpm

**Flash durations**

- 100 / 250/500 ms
- CASA compliant flash durations (2/3 ON, 1/3 OFF)

**Flash modes**

- All outputs simultaneously
- ICAO sequential flash for 3 light unit
- FAA sequential flash for 3 light unit
- German BMVBW -flash sequency
- Polish sequential flash for 3 light units

Order code:

- CEL-CSW-24-02-F
- CEL-CSW-24-02-GPS
- CEL-CSW-24-02-GSM
- CEL-CSW-24-02-GSM-GPS

Made in EU

Technical information in this document is subject to change without notice. Copyright © CEL 2007

**24 V<sub>DC</sub> fault monitoring and flash controller unit****Description of operation:**

The CSW measures the current consumption of the outputs in use every 250 ms. If five consecutive measurements occur giving overcurrent fault, an alarm is generated. If output current exceeds 0,5A, faulty output is turned OFF. After 30 minutes CSW will try to switch (faulty) output back on, making five measurements, and if the fault has been cleared, the alarm is turned off. If it is still faulty the alarm stays on. Alarm is also generated in case of power loss.

Remember always to check DIP-switch that the output limits are selected correctly.

You may connect several parallel light units to one output, but notice that you must calculate currents together to get the correct current limit, and alarms will only happen outside of those current limits.

The CSW DIP Switch table shows the available ranges for current alarms. For defining the normal current consumption for the system depends on the number and type of LED-lights used. The same table also shows how to enable and disable the photocell facility also selecting its light sensitivity.

If internal photocell is used, the CSW-unit must be installed outdoors.

**ICAO/FAA Sequential flash mode for 3-light unit**

According  
ICAO Aerodrome Design Manual, Part 4, Visual Aids, third edition - 1993 and FAA AC 150/5345-43E, 10/19/95

*Some cases, lighting systems requires both a unique, easily recognised, vertically coded flashing sequence, and the marking of two or more structures on either side of the flyway, e.g. river valley, major road, etc. While not absolutely necessary, synchronised flashing of all lighted structures is desirable.*

The middle level (output 2) flash first, the top level (output 1) flash second, and the bottom level (output 3) flash last. The interval between the flashing of the top level and bottom level is twice the interval between the middle level and the top level.

The interval between the end of one sequence and the beginning of the next is ten times the interval between the middle level and the top level. The time for the completion of one cycle is 1 second.

**German BMVBV Flash Sequency**

According BMVBV LS 11/60.01.87-01/5 Va 02, 24.  
September 2002, Page 15:  
1s on, 0,5s off, 1s on, 1,5 s off

**Polish Flash Sequency**

Sequential flash mode for 3-light unit  
Starting from bottom - middle - top, 20 fpm/light unit, total amount of flashes 60 fpm

**Multiple CSW's flash synchronisation**

UTC (Universal Time Code) -time from GPS-receiver maintain CSW real time clock correct time within 20 ms accuracy.

When real time clock is locked UTC-time, all CSW units around world start flash sequences exactly same time without any intervention between each other.

For example flash sequency according  
BMVBV LS 11/60.01.87-01/5 Va 02, 24. September 2002

Flash sequency starts 15 times/minute (on every fourth second), at full seconds below:

0, 4, 8, 12, 16, 20, 24, 28, 32, 36, 40, 44, 48, 52 and 56

24 V<sub>DC</sub> fault monitoring and flash controller unit

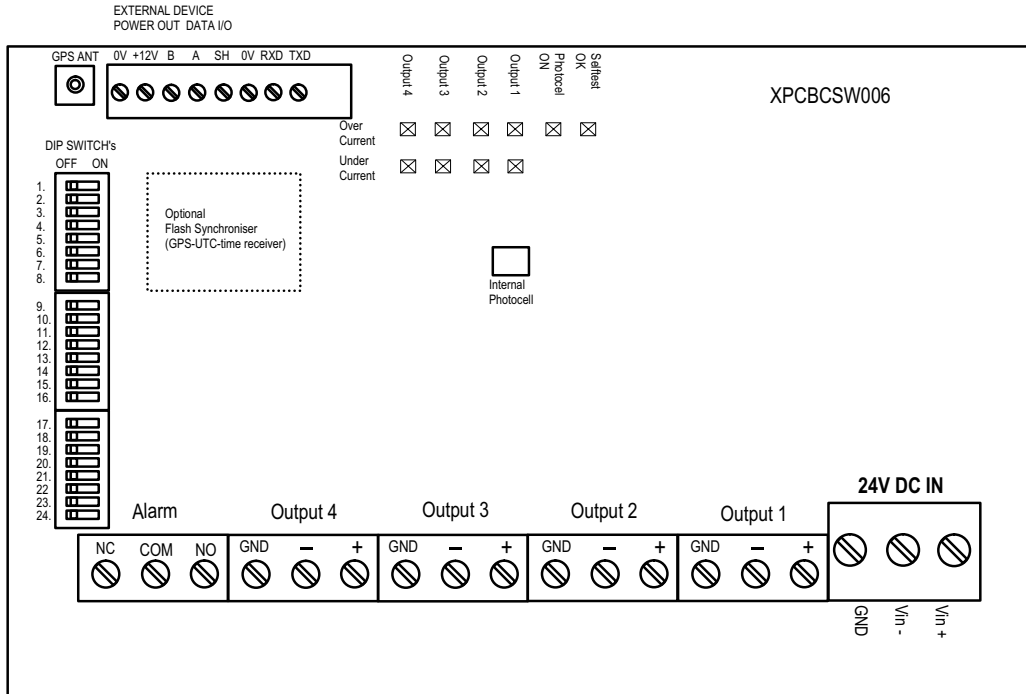

CEL-CSW-24-02-F Circuit Board

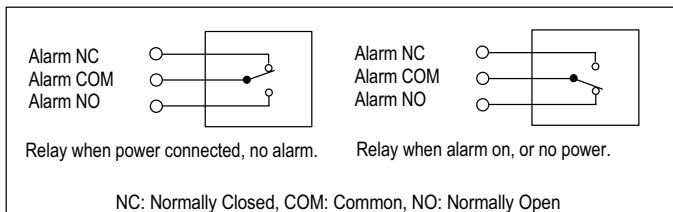

Alarm relay terminals: