

**115 V_{AC} ICAO Low-intensity, Type A Obstacle Light
with photocell & flasher**
Key features

- Based on LED-technology
- Extremely reliable - long lifetime
- Suitable for off-shore use
- Very low power consumption
- 115 V_{AC} nominal operating voltage
- Stabilised light output
- Lightweight and small – low wind load factor
- Easy to install, several mounting sets available
- Two cable glands, easy to chain without external terminal boxes
- No RF-radiations
- Five (5) years warranty

Benefits

- Long maintenance intervals
- Low energy cost
- Supply power voltage variations do not affect to light output
- Very low total lifetime costs
- Low wind load

Specifications met

- ICAO International Standards and Recommended Practices:
Aerodromes - Annex 14 Volume 1, 3rd Edition, July 1999,
Chapter 6: Low-intensity, Type A Fixed Obstacle Light

Optical characteristics

- Intensity better than 10 cd
- Colour aviation red
- Horizontal radiation pattern 360°
- Vertical radiation pattern 15°
- LED supply current stabilised by constant current generator
- Light output degradation less than 30% after 100.000 h of operation

Electrical characteristics

- Nominal operating voltage 115 V_{AC}
- Power consumption less than 3 VA, 1.5 W
- Operating voltage range 105 to 125 V_{AC}
- Over-voltage protection

Mechanical characteristics

- Anodised, marine grade aluminium body and end parts
- AISI 316 acid proof steel screws
- Colourless (clear) glass cover
- Terminal box for 1,5 - 6 mm² wires
- Degree of protection IP 65
- Operating temperature range -55°C to +55°C
- Height 210 mm, diameter 104 mm, weight 1.1 kg
- Wind load with CEL-MS-EV60 mounting kit @ 200 km/h less than 40 N

Options

- Mounting kits
- Light unit without Photocell & Flasher: CEL-LI-10-115-F

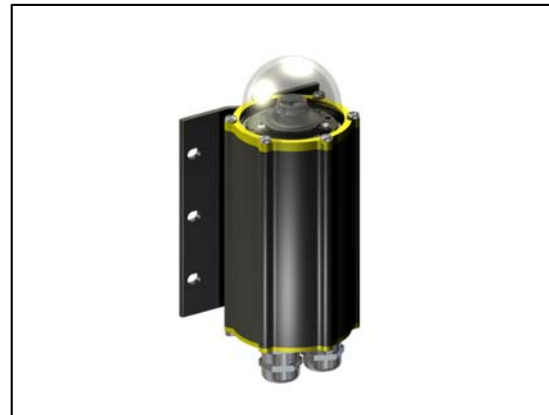
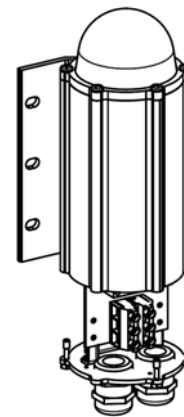
Order Code: CEL-LI-10-115-PCFL

CEL-LI-10-115-PCFL LED obstacle light

Photocell characteristics

- Turn on delay 1 s
- Turn off delay 200 s
- User selectable photocell sensitivity (bold = factory default)
OFF/200 lux / 400 lux / **800 lux**

Flash controller characteristics

- User selectable flashing rate (bold = factory default)
Steady burning / 20 fpm / 40 fpm / 60 fpm
- 250 ms flash duration



Technical information in this document is subject to change without notice. Copyright © CEL 2006

**115 V_{AC} ICAO Low-intensity, Type A Obstacle Light
with photocell & flasher**

ELECTRICAL INSTALLATION INSTRUCTIONS

CEL-LI-10-115-PCFL have two cable gland for easy chaining without external distribution boxes

CEL-LI-10-115-PCFL is an obstacle light utilising LED technology. The cabling and installation principles are similar to those of conventional obstacle lights.

Connection can be protected with a 6 A or 10 A fuse or with a circuit breaker (C curve).

Installation specifications

- Cable gland: M25
- Cable diameter: 11 to 17 mm
- Wire diameter: max. 6 mm²
- Recommended cable: 3x1.5 mm² or 3x2.5 mm²

Options

- **CGS-20:** Smaller cable glands
Set include 2 pcs M20 gable glands with M25-M20 adapters for 7-13 mm cables

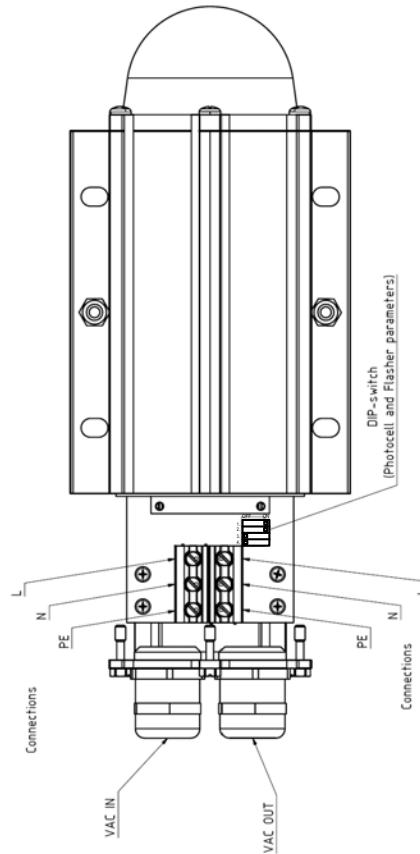

PCFL DIP switches

DIP1	DIP2	PHOTOCELL
OFF	OFF	OFF (light always ON)
ON	OFF	200 lux
OFF	ON	400 lux
ON	ON	800 lux

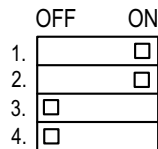

**Default DIP settings:
800 lux, steady burning**

DIP3	DIP4	FLASH RATE
OFF	OFF	STEADY BURNING
ON	OFF	20 fpm
OFF	ON	40 fpm
ON	ON	60 fpm

Flash Duration 250 ms

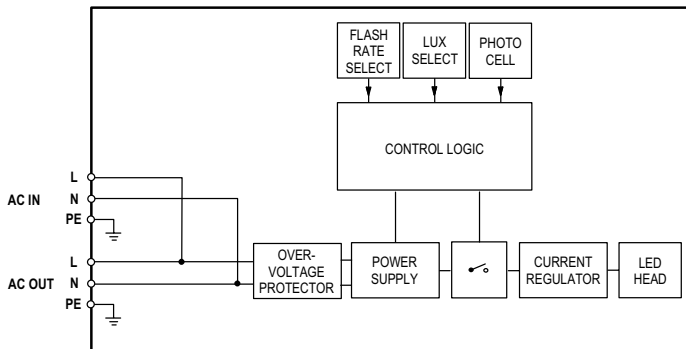

CEL-LI-10-115-PCFL block diagram

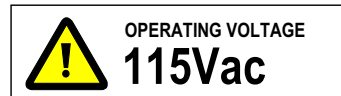

Technical information in this document is subject to change without notice. Copyright © CEL 2006

115 V_{AC} ICAO Low-intensity, Type A Obstacle Light
with photocell & flasher

Mechanical dimensions

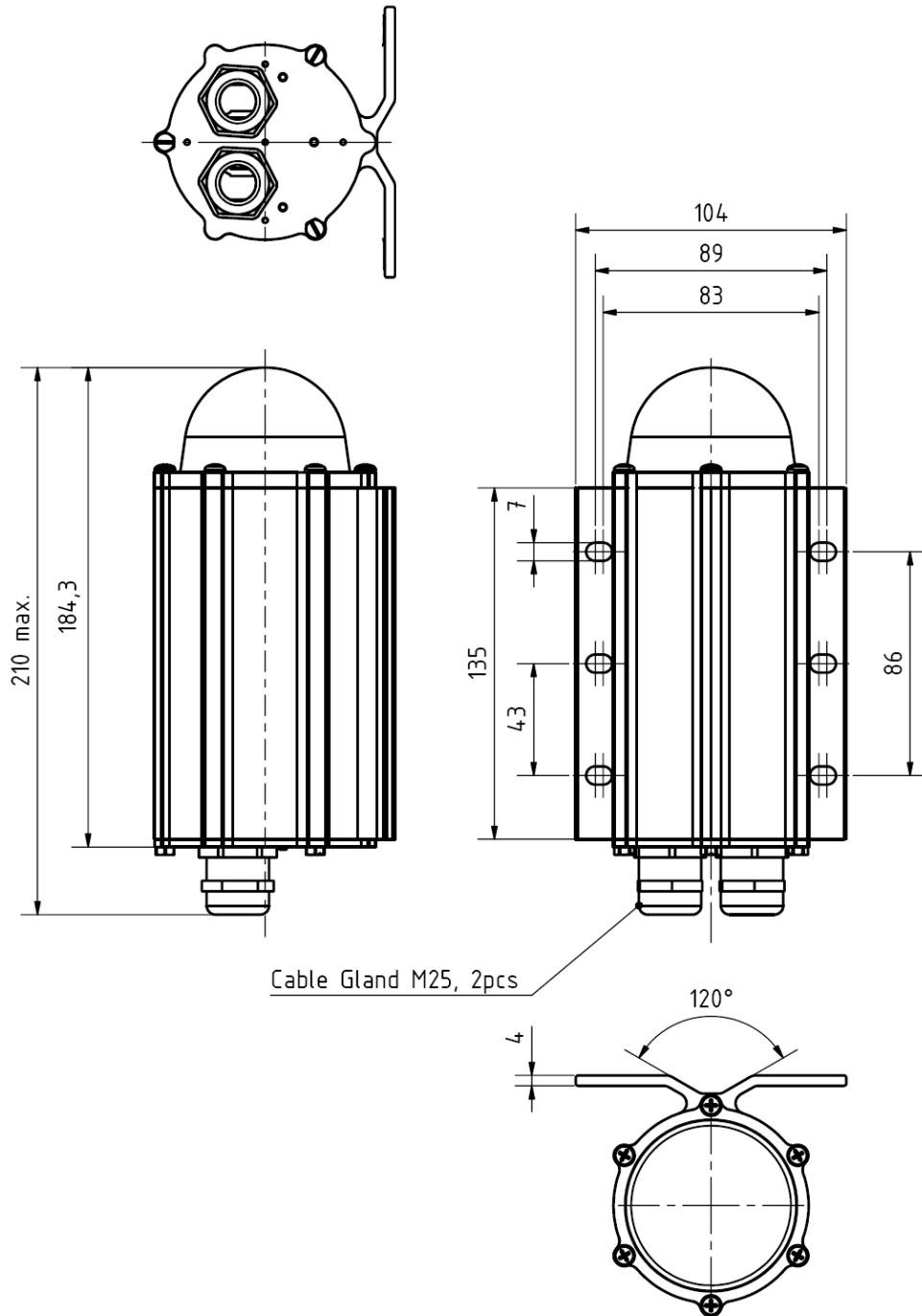

Technical information in this document is subject to change without notice. Copyright © CEL 2006

**115 V_{AC} ICAO Low-intensity, Type A Obstacle Light
with photocell & flasher**

There are several types of mounting sets available as option:

CEL-MS-HV80

Mounting set for 33-80 mm vertical or horizontal pipe

MS-HV mounting set includes:

- 2 pcs M6 U-bolt
- 8 pcs M6 hex nut
- 4 pcs 6/12 mm washer

All parts AISI 316 acid proof steel

More detailed mechanical data: CEL-MS-HV80 datasheet

Order Code: **CEL-MS-HV80**

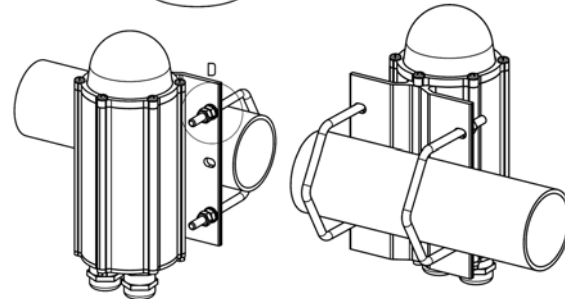
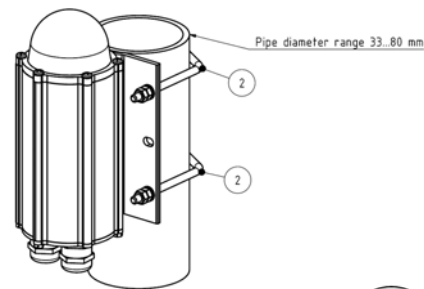
**CEL-MS-EV60**

Mounting set with extension plate
for 30-60 mm vertical pipe installation

Mounting set includes:

- 2 pcs M8 U-bolt, 8 pcs M8 hex nut
- 4 pcs M6x30 bolt, 8 pcs M6 hex nut, 4 pcs 6/12 washer
- 1 pcs extension plate

Extension plate marine grade anodised aluminium,
other parts AISI 316 acid proof steel

More detailed mechanical data: CEL-MS-EV60 datasheet

Order Code: **CEL-MS-EV60**

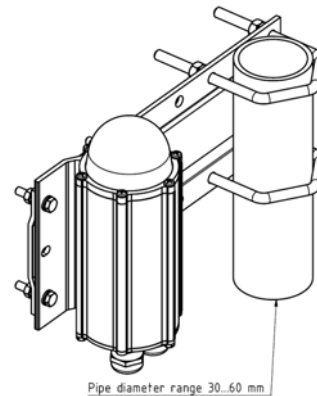
**CEL-MS-EV100:**

Mounting set with extension plate
for 60-100 mm vertical pipe installation

Mounting set includes:

- 2 pcs M8 U-bolt, 8 pcs M8 hex nut
- 4 pcs M6x30 bolt, 8 pcs M6 hex nut, 4 pcs 6/12 washer
- 1 pcs extension plate

Extension plate marine grade anodised aluminium,
other parts AISI 316 acid proof steel

More detailed mechanical data: CEL-MS-EV100 datasheet

Order Code: **CEL-MS-EV100**

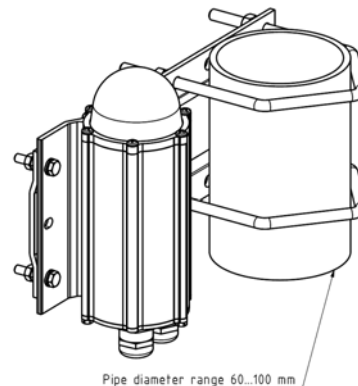

Technical information in this document is subject to change without notice. Copyright © CEL 2006

**115 V_{AC} ICAO Low-intensity, Type A Obstacle Light
with photocell & flasher****CEL-MS-EV150:**

Mounting set with extension plate
for 100-150 mm vertical pipe installation

Mounting set includes:

- 2 pcs M8 U-bolt, 8 pcs M8 hex nut
- 4 pcs M6x30 bolt, 8 pcs M6 hex nut, 4 pcs 6/12 washer
- 1 pcs extension plate

Extension plate hot dipped galvanised steel,
other parts AISI 316 acid proof steel

More detailed mechanical data: CEL-MS-EV150 datasheet

Order Code: **CEL-MS-EV150**

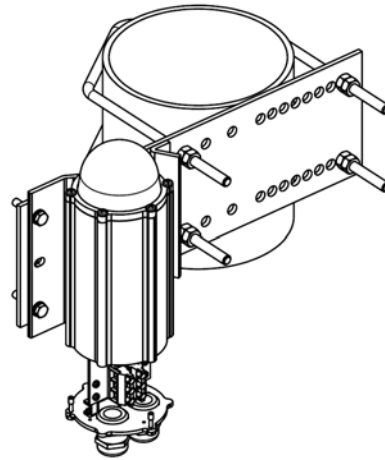
**CEL-MS-DV60:**

Double mounting set with extension plate
for 30-60 mm vertical pipe installation

Mounting set includes:

- 2 pcs M8 U-bolt, 8 pcs M8 hex nut
- 8 pcs M6x30 bolt, 16 pcs M6 hex nut, 8 pcs 6/12 washer
- 1 pcs extension plate

Extension marine grade anodised aluminium,
other parts AISI 316 acid proof steel

More detailed mechanical data: CEL-MS-DV60 datasheet

Order Code: **CEL-MS-DV60**

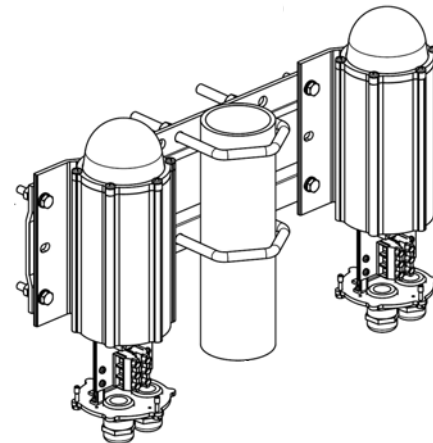
**CEL-MS-DV100:**

Double mounting set with extension plate
for 60-100 mm vertical pipe installation

Mounting set includes:

- 2 pcs M8 U-bolt, 8 pcs M8 hex nut
- 8 pcs M6x30 bolt, 16 pcs M6 hex nut, 8 pcs 6/12 washer
- 1 pcs extension plate

Extension marine grade anodised aluminium,
other parts AISI 316 acid proof steel

More detailed mechanical data: CEL-MS-DV100 datasheet

Order Code: **CEL-MS-DV100**

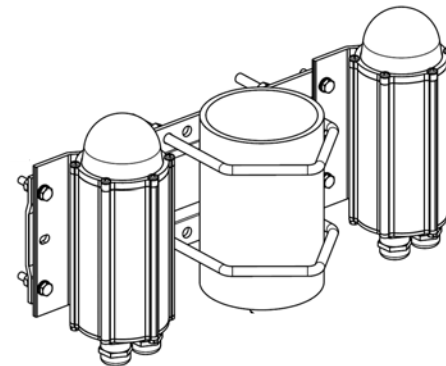

Technical information in this document is subject to change without notice. Copyright © CEL 2006

**115 V_{AC} ICAO Low-intensity, Type A Obstacle Light
with photocell & flasher****CEL-MS-RW**

Mounting set for horizontal plate or wall installation

Mounting set includes:

- 4 pcs M6x30 bolt, 8 pcs M6 hex nut, 4 pcs 6/12 washer
- 1 pcs L-shape 2 mm plate

All parts AISI 316 acid proof steel

More detailed mechanical data: CEL-MS-RW datasheet

Order Code: **CEL-MS-RW**

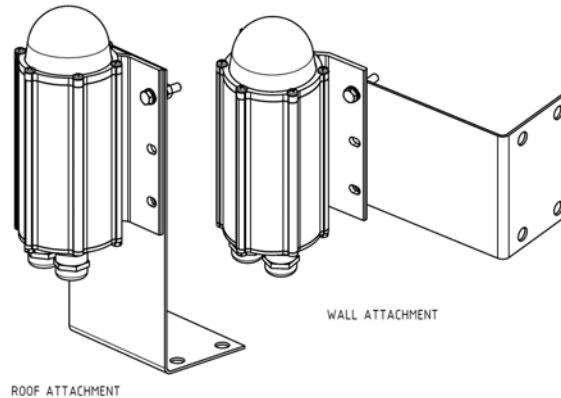
**CEL-MS-LVU**

Mounting set for L and V -shape profiles

Mounting set includes

- 1 set accessories for light unit fitting to plate
- 1 pcs extension plate with adjusting plate and accessories

Extension plate hot dip galvanised steel, other parts

AISI 316 acid proof steel

More detailed mechanical data: CEL-MS-LVU datasheet

Order Code: **CEL-MS-LVU**

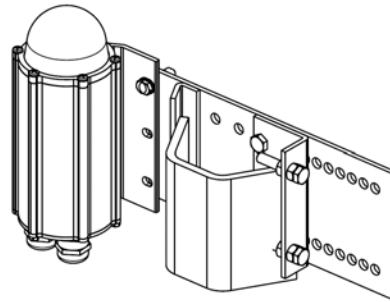
**CEL-MS-N1B**

Mounting set for 1" NPT at bottom

More detailed mechanical dimensions: CEL-MS-N1B dataheet

Order Code: **CEL-MS-N1B**

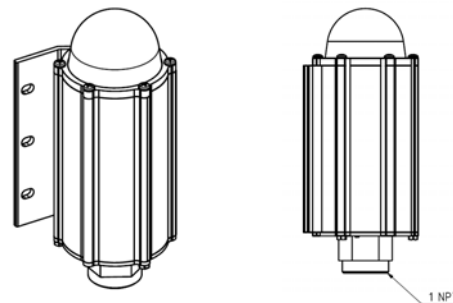

Technical information in this document is subject to change without notice. Copyright © CEL 2006